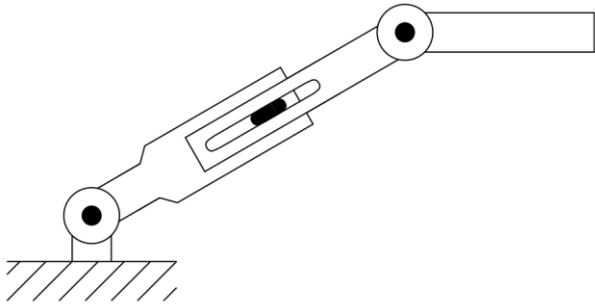
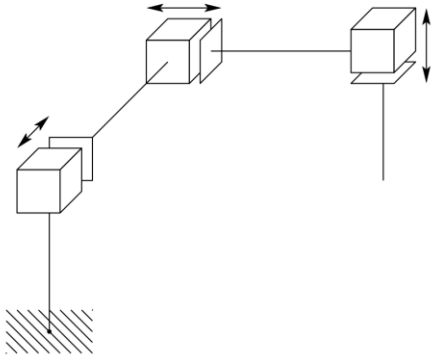
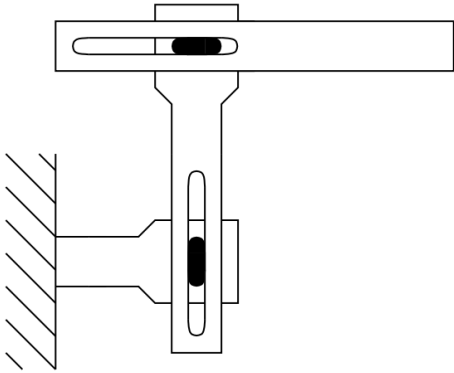
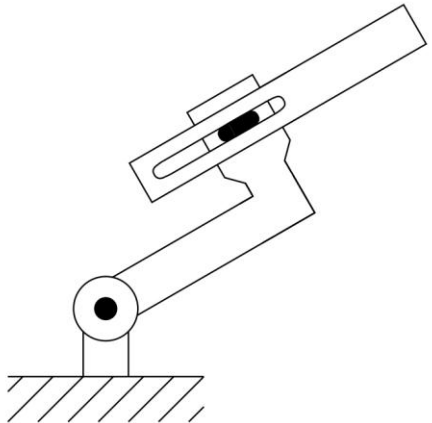
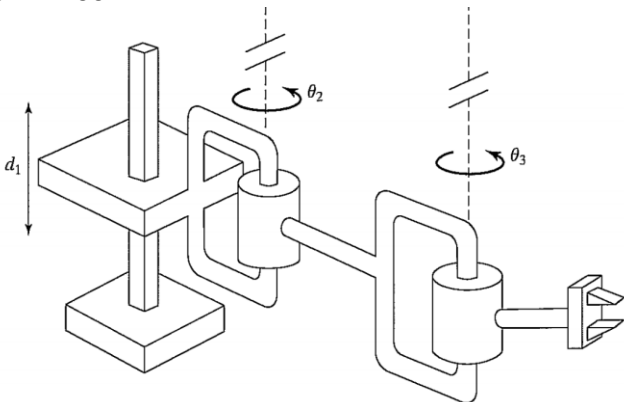
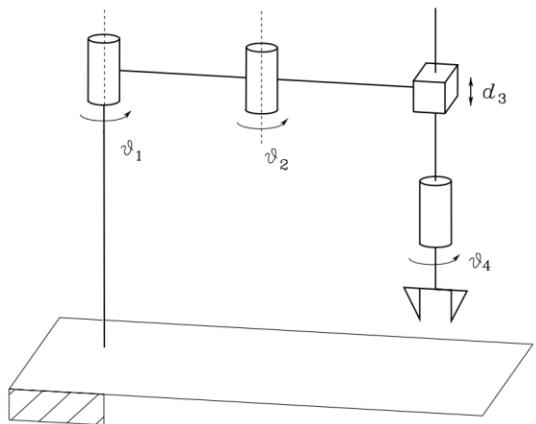

تمرین سری دوم رباتیک پیشرفته

مهلت تحویل: ۴ خرداد

در سوالات ۱ تا ۷، سینماتیک مستقیم ربات‌ها را براساس روابط DH استخراج نمایید.

<p>1- Three-link planar arm with prismatic joint</p> 	<p>2- Three-link Cartesian robot</p> 
<p>3- Two-link Cartesian robot</p> 	<p>4- Two-link planar arm</p> 
<p>5- Three link PRR</p> 	<p>6- SCARA manipulator</p> 

7- Puma Robot

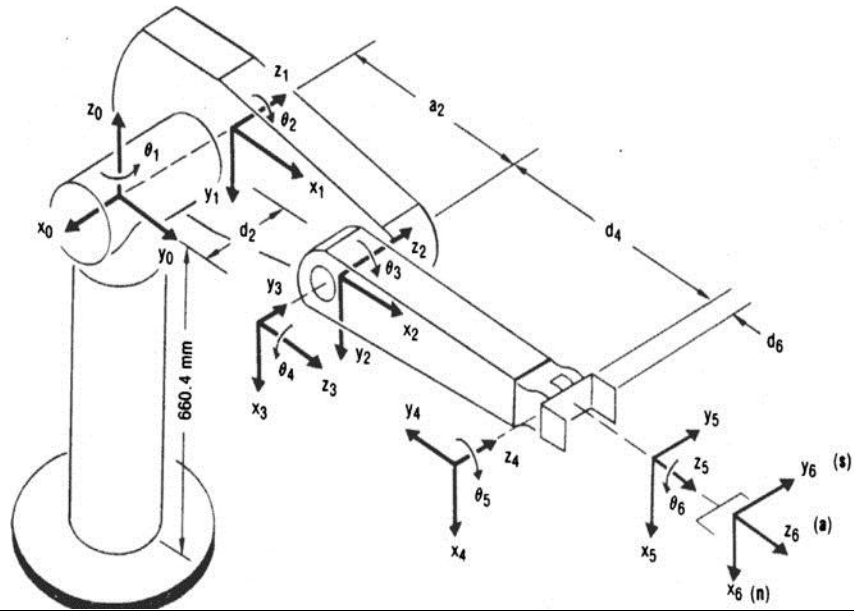

در سوالات ۸ و ۹، سینماتیک معکوس ربات‌ها را حل نمایید.

8- Cylindrical arm

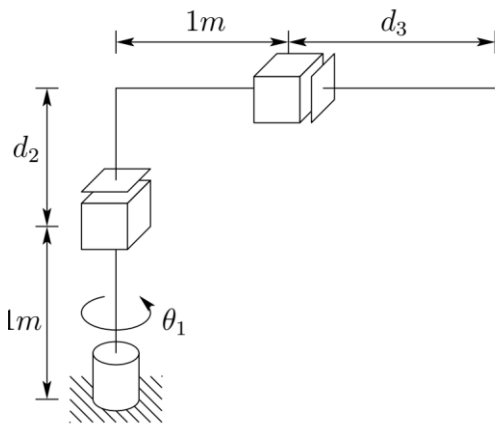

9- Cartesian configuration

